

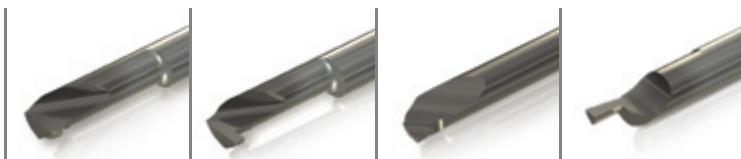

microscope
Micro Tools For Small Bores



METRIC

microscope

New Family of Micro Single Ended Tools

The **Microscope** line offers new and improved solutions for micro grooving, boring and threading in bores as small as 1.0 mm.

The **Microscope** line offers a large range of new single-ended inserts and a full range of tool holders with a simple clamping system.

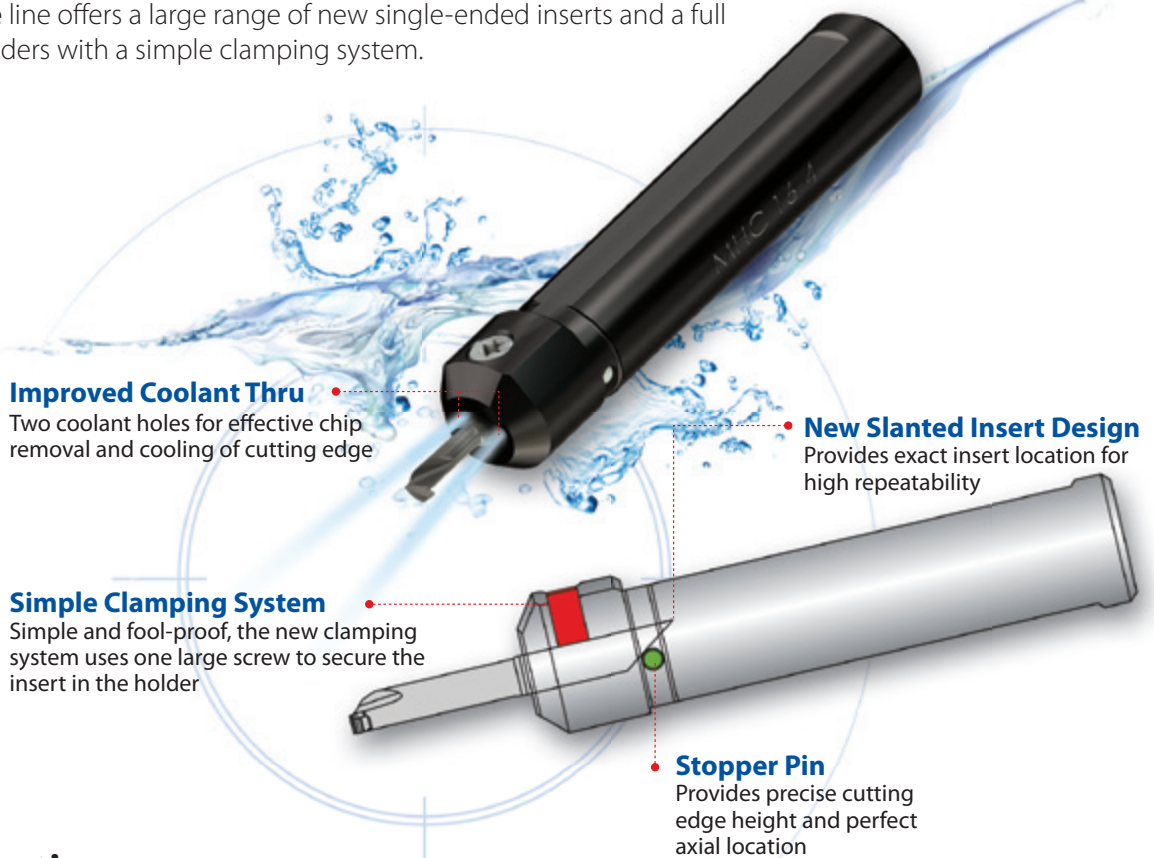

Improved Coolant Thru
Two coolant holes for effective chip removal and cooling of cutting edge

New Slanted Insert Design
Provides exact insert location for high repeatability

Simple Clamping System
Simple and fool-proof, the new clamping system uses one large screw to secure the insert in the holder

Stopper Pin
Provides precise cutting edge height and perfect axial location

Applications

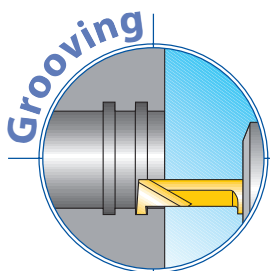

- Square
- Round
- Internal Face Grooving
- External Face Grooving

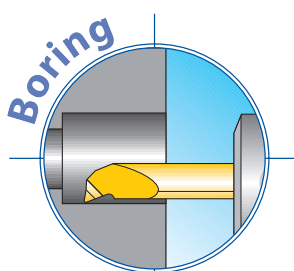

- Bore
- Copy Long Nose

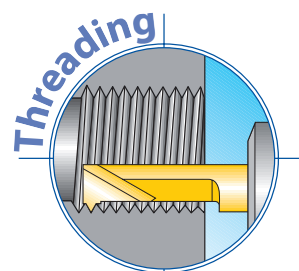

- ISO
- UN
- Whitworth
- NPT
- Partial 60°
- Partial 55°

VBX A New and Improved Grade for the Microscope Line
A tough sub-micron substrate with TiCN coating for general use, VBX provides good fracture toughness and excellent wear resistance

microscope CATALOG









■	Microscope Ordering Code System	Page 4
INSERTS		
GROOVING		
■	Square Groove	Page 5
■	Round Groove	Page 6
■	Face Grooving Internal	Page 7
■	Face Grooving External	Page 7
■	Pre-Part Off	Page 8
BORING		
■	Boring	Page 9
■	Copy (Long Nose)	Page 11
THREADING		
■	Threading – Partial Profile 60°	Page 12
■	Threading – Partial Profile 55°	Page 12
■	Threading – ISO Metric	Page 13
■	Threading – American UN	Page 13
■	Threading – NPT	Page 14
■	Threading – Whitworth	Page 14
TOOLHOLDERS		
■	Round Shank	Page 15
■	Square Shank	Page 16
TECHNICAL DATA		
■	Grooving Technical Data	Page 17
■	Boring Technical Data	Page 18
■	Threading Technical Data	Page 19

microscope Ordering Code System

microscope Insert Ordering Code

M	5	42	TH	0.5	ISO	L16	R/L	VBX
1	2	3	4	5	6	7	8	9

1 - Product Line	2 - Insert Size	3 - Min. Bore dia. (mm)
M - Microscope	4, 5, 6, 7	1.7, 2.2, 3.2,.....

4 - Type of Application	
GS-Grooving Square	
GR-Grooving Round	
FG-Face Grooving Internal	
FP-Face Grooving External	
PP-Pre Part Off	
BC-Boring	
CL-Copy Long Nose	
TH-Threading	

5 - Pitch (for Threading)	
Full Profile - Pitch Range	
mm	tpi
0.5 - 1.5	28-18
Partial Profile - Pitch Range	
mm	tpi
A 0.5 - 1.5	A 48-16
F 0.5 - 1.0	F 48-24
5 - Width / Radius (for Grooving)	
Width	Radius
1.0-3.0(mm)	0.5-1.0(mm)
5 - Nose Radius (for Boring)	
0.1, 0.15, 0.2 (mm)	

6 - Threading Standard
ISO - ISO Metric
UN - American UN
W - Whitworth for BSW, BSP
NPT - NPT
60° - Partial Profile 60°
55° - Partial Profile 55°

7 - Overhang Length (mm)	8 - RH or LH	9 - Carbide Grade
L16, L20...	R - RH L - LH	VBX

microscope Toolholders Ordering Code

MH	C	16	-	7
1	2	3		4

1 - Product Line	2 - Cooling	3 - Shank Size (mm)	4 - Insert Size (mm)
MH - Microscope Holder MHS - Microscope Holder with Square Shank	C - Coolant Thru	10, 12, 16, 20	4, 5, 6, 7

Square Groove

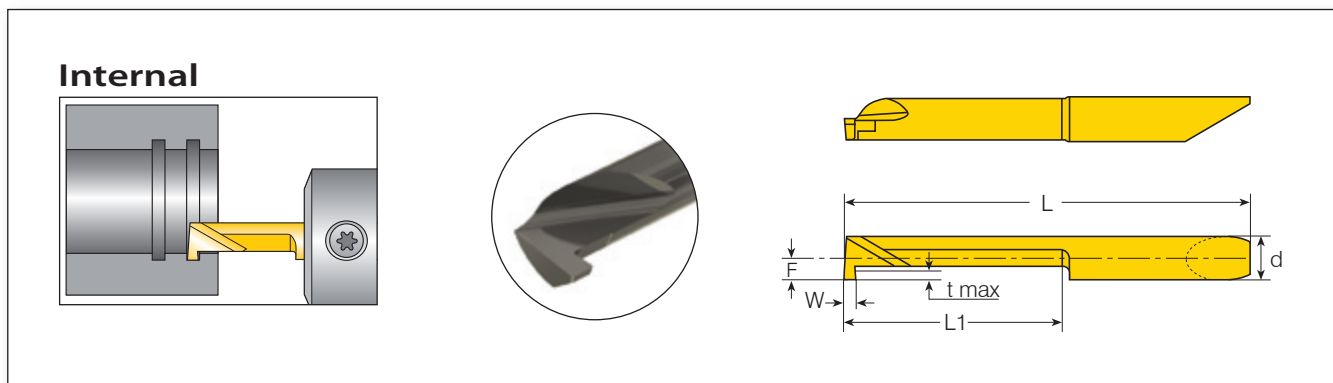

Groove Dimensions (mm)		Insert dia.	Ordering Code	Dimensions mm			Min. Bore dia.	Toolholder
W± 0.025	t max	d(mm)	RH /LH	L1	L	F	mm	
1.0	0.8	4.0	M442GS W100 L10R/L	10	35	2.0	4.2	MHC...-4
			M442GS W100 L15R/L	15	41			
			M442GS W100 L20R/L	20	46			
1.0	1.0	5.0	M552GS W100 L10R/L	10	35	2.5	5.2	MHC...-5
M552GS W100 L15R/L			15	41				
M552GS W100 L20R/L			20	46				
1.5			M552GS W150 L10R/L	10	35			
M552GS W150 L15R/L			15	41				
M552GS W150 L20R/L			20	46				
2.0			M552GS W200 L10R/L	10	35			
M552GS W200 L15R/L			15	41				
M552GS W200 L20R/L			20	46				
1.0	1.8	6.0	M662GS W100 L10R/L	10	36	3.0	6.2	MHC...-6
M662GS W100 L15R/L			15	42				
M662GS W100 L20R/L			20	47				
M662GS W100 L30R/L			30	56				
1.5			M662GS W150 L10R/L	10	36			
M662GS W150 L15R/L			15	42				
M662GS W150 L20R/L			20	47				
M662GS W150 L30R/L			30	56				
2.0			M662GS W200 L10R/L	10	36			
M662GS W200 L15R/L			15	42				
M662GS W200 L20R/L			20	47				
M662GS W200 L30R/L			30	56				
1.0	2.5	7.0	M772GS W100 L10R/L	10	36	3.5	7.2	MHC...-7
M772GS W100 L15R/L			15	41				
M772GS W100 L25R/L			25	51				
M772GS W100 L35R/L			35	61				
1.5			M772GS W150 L10R/L	10	36			
M772GS W150 L15R/L			15	41				
M772GS W150 L25R/L			25	51				
M772GS W150 L35R/L			35	61				
2.0			M772GS W200 L10R/L	10	36			
M772GS W200 L15R/L			15	41				
M772GS W200 L25R/L			25	51				
M772GS W200 L35R/L			35	61				

Round Groove

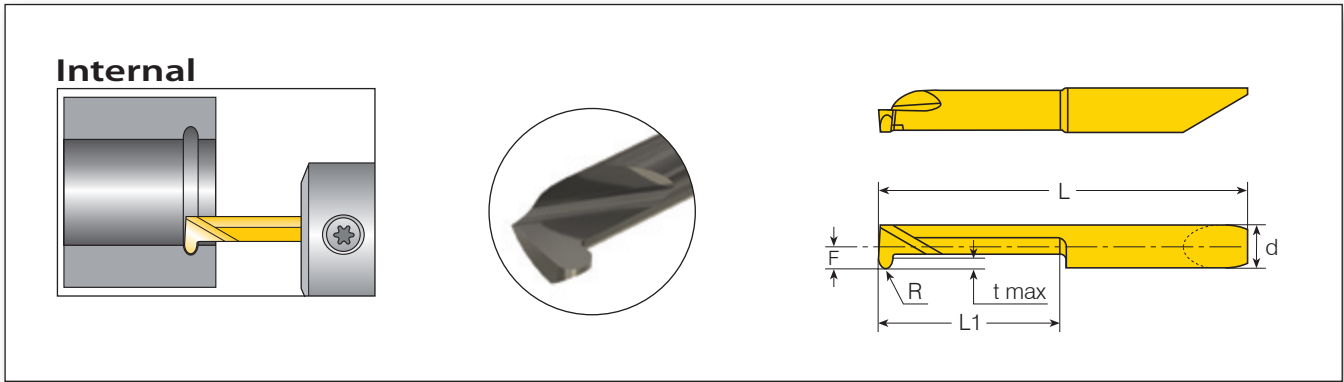

Groove Dimensions (mm)		Insert dia.	Ordering Code	Dimensions (mm)				Min. Bore dia.	Toolholder
W±0.025	t max	d(mm)	RH /LH	R	L1	L	F	mm	
1.0	0.8	4.0	M442GR R050 L15R/L	0.5	15	39	1.95	4.2	MHC ..-4
1.0	1.0	5.0	M552GR R050 L20R/L	0.5	20	46	2.45	5.2	MHC ..-5
1.5			M552GR R075 L20R/L	0.75		46			
2.0	1.8	6.0	M662GR R050 L25R/L	0.5	25	52	2.95	6.2	MHC ..-6
1.0			M662GR R075 L25R/L	0.75		52			
1.5			M662GR R100 L25R/L	1.0		52			
2.0									

Face Grooving Internal



Groove Dimensions (mm)		Insert dia.	Ordering Code	Dimensions mm				Min. Bore dia.	Toolholder
W±0.025	t max	d(mm)	RH /LH	R	L1	L	F	mm	
1.0	2	6.0	M662FG W10 L15R/L	0.1	15	42	2.95	6.2	MHC...-6
1.5	3		M662FG W15 L15R/L						
2.0	4		M662FG W20 L15R/L						
2.5	5		M662FG W25 L15R/L						
3.0	6		M662FG W30 L15R/L						

Face Grooving External

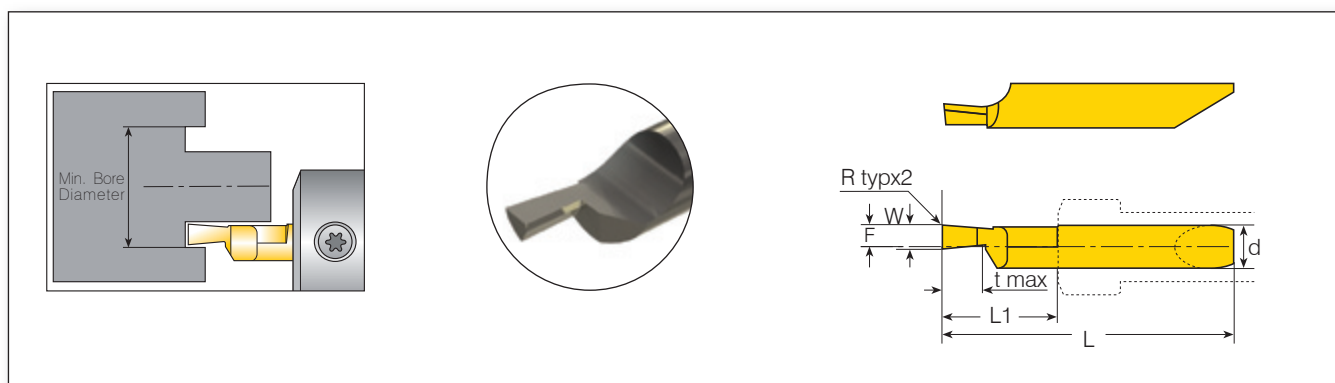

Groove Dimensions (mm)		Insert dia.	Ordering Code	Dimensions mm				Min. Bore dia.	Toolholder
W±0.025	t max	d(mm)	RH /LH	R	L1	L	F	mm	
1.0	2	6.0	M662FP W10 L15R/L	0.1	15	42	2.95	6.2	MHC...-6
1.5	3		M662FP W15 L15R/L						
2.0	4		M662FP W20 L15R/L						
2.5	5		M662FP W25 L15R/L						
3.0	6		M662FP W30 L15R/L						

Pre-Part Off

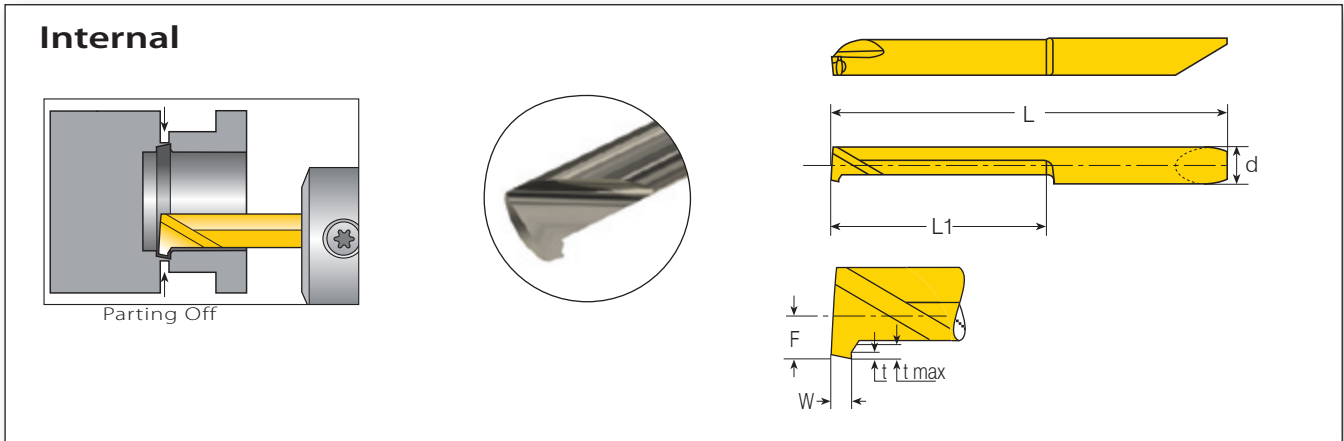

Groove Dimensions (mm)		Insert dia.	Ordering Code	Dimensions (mm)			Min. Bore dia.		Toolholder
W	t max	d(mm)	RH /LH	t	L1	L	F	mm	
1.0	0.7	5.0	M552PP W100 L15R/L	0.3	15	41	2.45	5.2	MHC..-5
			M552PP W100 L20R/L		20	46			
			M552PP W100 L25R/L		25	51			
			M552PP W100 L30R/L		30	55			

Boring

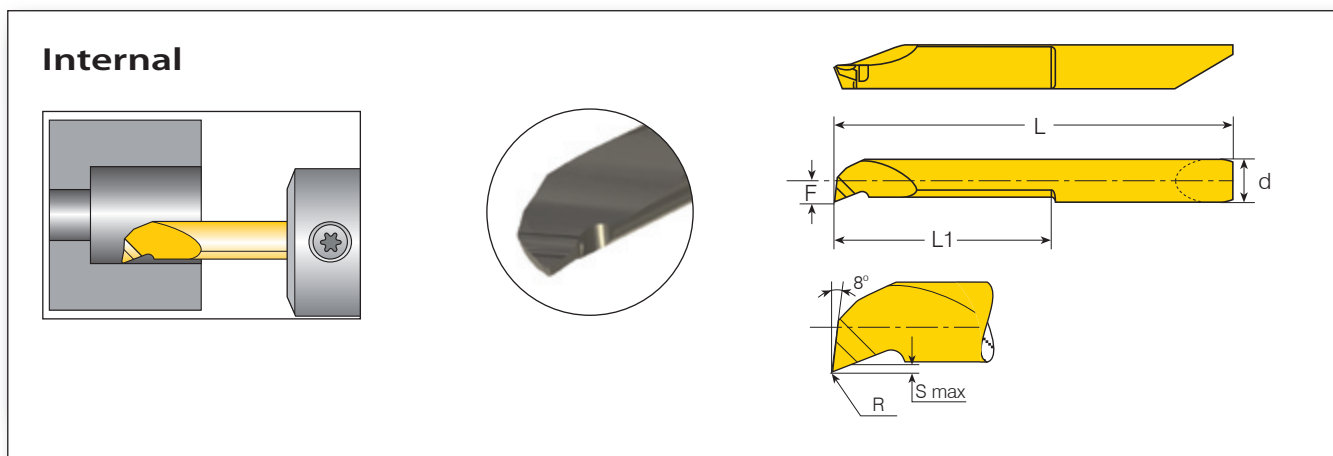

Insert dia.	Ordering Code	Dimensions mm					Min. Bore Dia.	Toolholder
d (mm)	RH / LH	R	L1	L	S max	F	mm	
4	M410BC R05 L04R/L	0.05	4	24.5	0.1	1.06	1	MHC.-4
	M410BC R10 L04R/L		4	24.5	0.1			
	M410BC R10 L06R/L		6	24	0.15	1		
	M415BC R10 L09R/L	9	27	0.2	0.5	1.5		
	M417BC R10 L06R/L	0.1	6	28	0.2	0.56	1.7	
	M417BC R10 L09R/L		9	28	0.15	0.3		
	M422BC R10 L06R/L	0.1	6	28	0.2	0.04	2.2	
	M422BC R10 L09R/L		9	28	0.15			
	M422BC R10 L14R/L		14	33	0.15	0.1		
	M427BC R15 L10R/L	0.1	10	28	0.2	0.44	2.7	
	M427BC R15 L15R/L		15	33		0.74	3	
	M430BC R15 L20R/L		20	39	0.15	0.9	3.2	
	M432BC R15 L10R/L	0.15	10	28	0.15	0.9	3.2	
	M432BC R15 L16R/L		16	33				
	M432BC R15 L20R/L		20	39				
	M437BC R15 L10R/L	0.15	10	28	0.2	1.45	3.7	
	M437BC R15 L15R/L		15	33				
	M437BC R15 L20R/L		20	39				
	M442BC R15 L10R/L	0.15	10	28	0.3	1.95	4.2	
	M442BC R15 L16R/L		16	33				
M442BC R15 L21R/L	21		39					
M442BC R15 L26R/L	26		45					

Boring

Internal

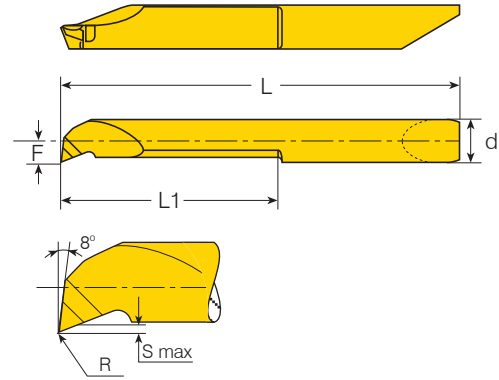
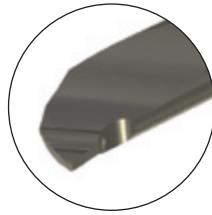
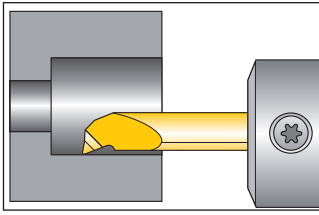

Insert dia.	Ordering Code	Dimensions mm					Min. Bore Dia.	Toolholder
d (mm)	RH / LH	R	L1	L	S max	F	mm	
5	M552BC R20 L10R/L	0.2	10	35	0.5	2.45	5.2	MHC..-5
	M552BC R20 L16R/L		16	41				
	M552BC R20 L21R/L		21	46				
	M552BC R20 L26R/L		26	51				
	M552BC R20 L30R/L		30	55				
	M552BC R20 L35R/L		35	60				
6	M662BC R20 L16R/L	0.2	16	42	0.5	2.95	6.2	MHC..-6
	M662BC R20 L21R/L		21	47				
	M662BC R20 L26R/L		26	52				
	M662BC R20 L30R/L		30	56				
	M662BC R20 L35R/L		35	61				
	M662BC R20 L40R/L		40	66				
7	M772BC R20 L25R/L	0.2	25	51	0.5	3.45	7.2	MHC..-7
	M772BC R20 L35R/L		35	61				
	M772BC R20 L40R/L		40	66				
	M772BC R20 L45R/L		45	71				
	M772BC R20 L50R/L		50	76				

Copy (Long Nose)

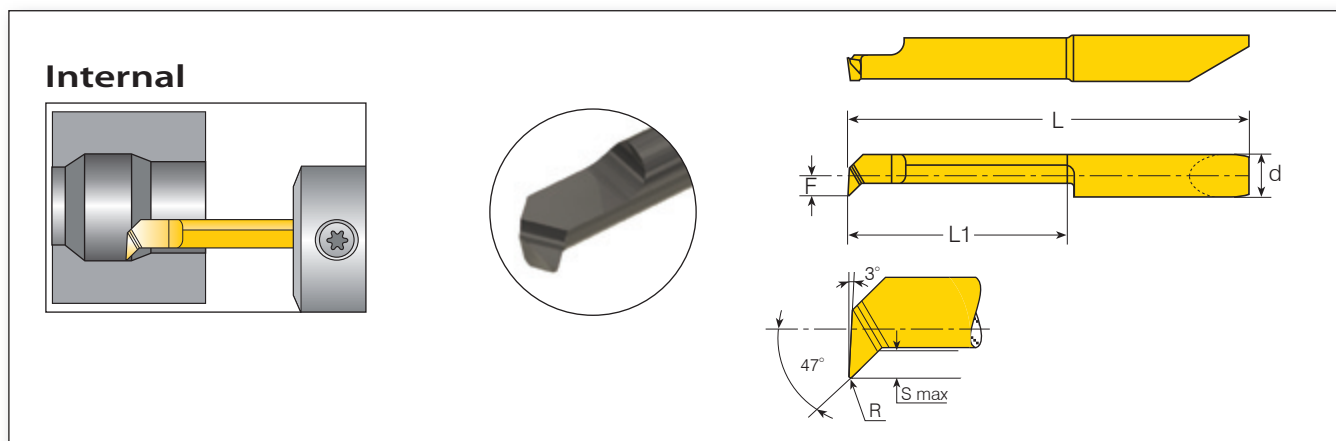

Insert dia. (mm)	Ordering Code RH / LH	Dimensions mm					Min. Bore Dia. mm	Toolholder
		R	L1	L	S max	F		
4.0	M442CL R15 L10R/L	0.15	10	28	0.75	1.95	4.2	MHC..-4
	M442CL R15 L16R/L	0.15	16	33				
	M442CL R15 L21R/L	0.15	21	39				
5.0	M552CL R20 L16R/L	0.2	16	41	0.95	2.45	5.2	MHC..-5
	M552CL R20 L25R/L	0.2	25	51				
6.0	M662CL R20 L16R/L	0.2	16	42	1.75	2.95	6.2	MHC..-6
	M662CL R20 L21R/L	0.2	21	47				
	M662CL R20 L30R/L	0.2	30	56				

Threading

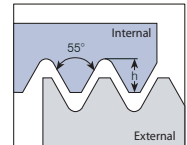
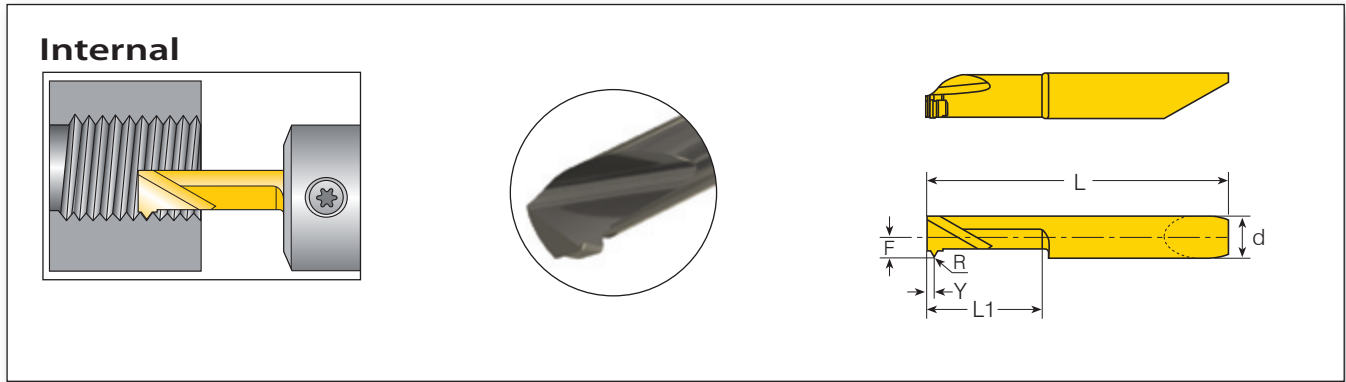

Partial Profile 55°

Insert dia.		Pitch		Ordering Code		Dimensions mm				Min. Bore dia.		Toolholder
d (mm)	mm	tpi	RH / LH	R	L1	L	F	Y	h (max)	mm		
4.0	0.5-1.0	48-24	M429TH F55 L16R/L	0.05	16	33	0.9	0.75	0.76	3.2	MHC ..-4	
4.0	0.5-1.0	48-24	M439TH F55 L16R/L			33	1.9	0.75	0.76	4.2	MHC ..-4	
6.0	0.5-1.5	48-16	M659TH A55 L16R/L			42	2.9	0.9	1.49	6.2	MHC ..-6	

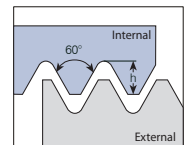

Partial Profile 60°

Insert dia.		Pitch		Ordering Code		Dimensions mm				Min. Bore dia.		Toolholder
d (mm)	mm	tpi	RH / LH	R	L1	L	F	Y	h (max)	mm		
4.0	0.5-1.0	48-24	M429THF60L16R/L	0.05	16	33	0.9	0.9	0.65	3.2	MHC..-4	
4.0	0.5-1.0	48-24	M439THF60L16R/L			33	1.9		0.76	4.2	MHC..-4	
6.0	0.5-1.5	48-16	M659THA60L16R/L			42	2.9		1.49	6.2	MHC..-6	

Threading

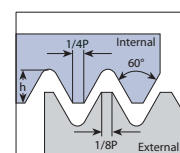

Defined by: R262 (DIN 13)
Tolerance class: 6g/6H

ISO Metric

Thread	Insert dia.	Pitch	Ordering Code	Dimensions mm					Min. Bore dia.	Toolholder
	d (mm)	mm	RH / LH	L1	L	F	Y	h (min)	mm	
M4x0.5	4.0	0.5	M429TH 0.50ISO L16R/L	16	33	0.9	0.4	0.29	3.4	MHC ..-4
M5x0.5		0.5	M439TH 0.50ISO L16R/L			1.9	0.4	0.29	4.4	
M4x0.7		0.7	M429TH 0.70ISO L16R/L			0.9	0.5	0.41	3.2	
M5x0.8		0.8	M429TH 0.80ISO L16R/L			0.9	0.6	0.46	4.0	
M6x1		1.0	M439TH 1.00ISO L16R/L			1.9	0.7	0.58	4.8	
M5.5x0.5	5.0	0.5	M542TH 0.50ISO L16R/L	16	41	1.7	0.4	0.29	4.9	MHC ..-5
M5.5x0.75		0.75	M542TH 0.75ISO L16R/L			0.6	0.43	4.6		
M7x1		1.0	M549TH 1.00ISO L16R/L			2.4	0.7	0.58	5.8	
M6x0.5	6.0	0.5	M649TH 0.50ISO L16R/L	16	42	1.9	0.4	0.29	5.4	MHC ..-6
M6.5x0.75		0.75	M649TH 0.75ISO L16R/L			0.6	0.43	5.6		
M7.5x1		1.0	M659TH 1.00ISO L16R/L			0.7	0.58	6.3		
M8x1.25		1.25	M659TH 1.25ISO L16R/L			2.9	0.9	0.72	6.5	
M10x1.5		1.5	M659TH 1.50ISO L16R/L			1.0	0.87	8.3		

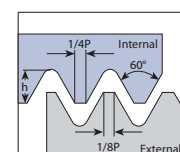

Defined by: ANSI B1.1:74
Tolerance class: 2A/2B

American UN

Thread	Insert dia.	Pitch	Ordering Code	Dimensions mm					Min. Bore dia.	Toolholder
	d (mm)	tpi	RH / LH	L1	L	F	Y	h (min)	mm	
No.8-32UNC	4.0	32	M429TH 32UN L16R/L	16	33	0.9	0.6	0.46	3.3	MHC..-4
No.10-28UNS		28	M429TH 28UN L16R/L			0.9	0.65	0.52	3.6	
1/4"-27UNS	5.0	27	M549TH 27UN L16R/L	16	41	2.4	0.75	0.54	5.3	MHC..-5
1/4"-24UNS		24	M542TH 24UN L16R/L			1.7	0.75	0.61	5.1	
1/4"-20UNC		20	M542TH 20UN L16R/L			1.7	0.9	0.73	4.6	
5/16"-18UNC	6.0	18	M659TH 18UN L16R/L	16	42	2.9	1.05	0.81	6.3	MHC..-6
3/8"-16UNC		16	M659TH 16UN L16R/L			2.9	1.0	0.92	7.7	

Threading

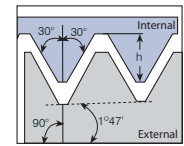

Defined by: USAS B2.1:1968
Tolerance class: Standard NPT

NPT

Thread	Insert dia.	Pitch	Ordering Code	Dimensions mm						Min. Bore dia.	Toolholder
	d (mm)	mm	RH / LH	L1	L	F	Y	h (min)	mm		
1/16"-27NPT	6.0	27	M659TH 27NPT L16R/L	16	42	2.9	0.75	0.66	6.1	MHC...-6	
1/4"-18NPT		18	M659TH 18NPT L16R/L								2.9

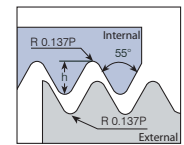



Defined by: B.S.84:1956, DIN 259,
ISO228/1:1982
Tolerance class: Medium Class A

Whitworth for BSW, BSP

Thread	Insert dia.	Pitch	Ordering Code	Dimensions mm						Min. Bore dia.	Toolholder
	d (mm)	tpi	RH / LH	L1	L	F	Y	h (min)	mm		
1/16"-28BSP	6.0	28	M659TH 28W L16R/L	16	42	2.9	0.65	0.58	6.5	MHC...-6	
1/4"-19BSP		19	M659TH 19W L16R/L								2.9

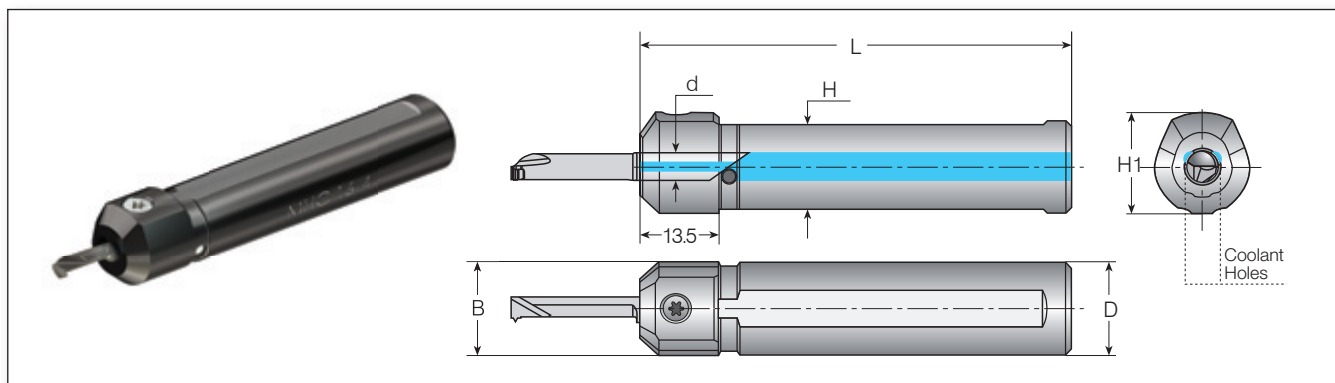

Toolholders - Round Shank

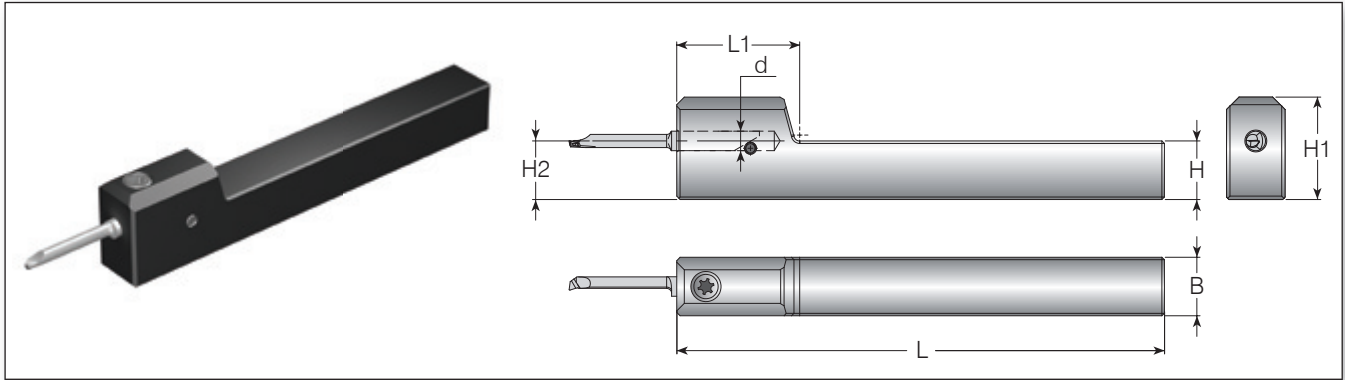

						Spare Parts	
Micro Insert Dia.	Ordering Code	Dimensions (mm)					
d(mm)		D=B	H1	H	L	Clamping Screw	Key
4.0	MHC 10-4	10	14	8.8	65	SL7DT15	KT15
	MHC 12-4	12	16	10.8	70		
	MHC 16-4	16	17.6	14.8	75		
	MHC 20-4	20	22	18.8	84		
5.0	MHC 10-5	10	14	8.8	65		
	MHC 12-5	12	16	10.8	70		
	MHC 16-5	16	18.6	14.8	75		
	MHC 20-5	20	22	18.8	84		
6.0	MHC 12-6	12	16	10.8	70		
	MHC 16-6	16	18.6	14.8	75		
	MHC 20-6	20	22	18.8	84		
7.0	MHC 16-7	16	18.6	14.8	75		
	MHC 20-7	20	22	18.8	84		

Toolholders - Microscope Holder with Square Shank



						Spare Parts	
Micro Insert Dia.	Ordering Code	Dimensions (mm)					
d(mm)		H=H2=B	H1	L	L1	Clamping Screw	Key
4.0	MHS 1010-4	10.0	19.0	100.0	25.0	SL7DT15	KT15
5.0	MHS 1010-5	10.0	19.5	100.0	25.0		
4.0	MHS 1212-4	12.0	21.0	100.0	25.0		
5.0	MHS 1212-5	12.0	21.5	100.0	27.0		
6.0	MHS 1212-6	12.0	22.0	100.0	27.0		

Grooving Technical Data

Recommended Grades, Cutting Speeds

Vc [m/min], Feed f [mm/rev]

Material Group	Vargus No.	Material	Hardness Brinell HB	Vc[m/min]* (Coated)	Feed f [mm/rev] VBX	
P Steel	1	Unalloyed steel	Low carbon (C=0.1-0.25%)	125	50-120	0.03
	2		Medium carbon (C=0.25-0.55%)	150	40-100	0.02
	3		High carbon (C=0.55-0.85%)	170	30-80	0.01
	4	Low alloy steel (alloying elements≤5%)	Non hardened	180	50-70	0.02
	5		Hardened	275	40-60	0.01
	6		Hardened	350	30-50	0.01
	7	High alloy steel (alloying elements>5%)	Annealed	200	30-50	0.02
	8		Hardened	325	25-40	0.01
	9	Cast steel	Low alloy (alloying elements <5%)	200	30-50	0.02
	10		High alloy (alloying elements >5%)	225	25-40	0.02
M Stainless Steel	11	Stainless steel Ferritic	Non hardened	200	60-100	0.01
	12		Hardened	330	40-60	0.01
	13	Stainless steel Austenitic	Austenitic	180	50-90	0.01
	14		Super Austenitic	200	40-60	0.01
	15	Stainless steel Cast Ferritic	Non hardened	200	40-60	0.02
	16		Hardened	330	30-50	0.01
	17	Stainless steel Cast austenitic	Austenitic	200	40-60	0.02
	18		Hardened	330	30-50	0.01
K Cast Iron	28	Malleable Cast iron	Ferritic (short chips)	130	50-70	0.02
	29		Pearlitic (long chips)	230	50-70	0.01
	30	Grey cast iron	Low tensile strength	180	50-70	0.02
	31		High tensile strength	260	40-60	0.15
	32	Nodular SG iron	Ferritic	160	50-70	0.02
	33		Pearlitic	260	60-80	0.01
N(K) Non-Ferrous Metals	34	Aluminium alloys Wrought	Non aging	60	100-300	0.03
	35		Aged	100	100-150	0.03
	36	Aluminium alloys	Cast	75	100-150	0.03
	37		Cast & aged	90	60-100	0.03
	38	Aluminium alloys	Cast Si 13-22%	130	100-150	0.02
	39	Copper and Copper alloys	Brass	90	60-100	0.03
40	Bronze and non leaded copper		100	60-100	0.03	
S(M) Heat Resistant Material	19	High temperature alloys	Annealed (Iron based)	200	25-45	0.01
	20		Aged (Iron based)	280	20-30	0.01
	21		Annealed (Nickel or Cobalt based)	250	15-20	0.01
	22		Aged (Nickel or Cobalt based)	350	10-15	0.01
	23	Titanium alloys	Pure 99.5 Ti	400Rm	60-100	0.02
24	α+β alloys		1050Rm	40-50	0.02	
H(K) Hardened Material	25	Extra hard steel	Hardened & tempered	45-50HRc	20-40	0.01
	26			51-55HRc	20-35	0.01

Carbide Grade - VBX



General use carbide grade for Microscope inserts. TiCN coated.

Machining Recommendation

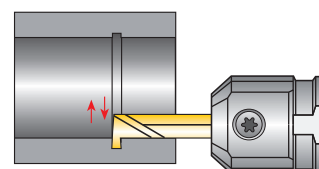

Machine the groove in one motion instead of intervals.

*Minimum cutting speed for small holes should be 25 m/min.

Boring Technical Data

Recommended Grades, Cutting Speeds

Vc [m/min], Feed f [mm/rev] and Max Depth [mm]

Material Group	Vargus No.	Material	Hardness Brinell HB	Vc[m/min]* (Coated)	Feed f [mm/rev] VBX	Max Depth [mm]	
P Steel	1	Unalloyed steel	Low carbon (C=0.1-0.25%)	125	50-120	0.05	0.4
	2		Medium carbon (C=0.25-0.55%)	150	40-100	0.04	0.4
	3		High carbon (C=0.55-0.85%)	170	30-80	0.03	0.4
	4	Low alloy steel (alloying elements ≤5%)	Non hardened	180	50-70	0.04	0.3
	5		Hardened	275	40-60	0.04	0.3
	6		Hardened	350	30-50	0.03	0.3
	7	High alloy steel (alloying elements >5%)	Annealed	200	30-50	0.04	0.15
	8		Hardened	325	25-40	0.03	0.15
	9	Cast steel	Low alloy (alloying elements <5%)	200	30-50	0.04	0.15
	10		High alloy (alloying elements >5%)	225	25-40	0.04	0.15
M Stainless Steel	11	Stainless steel Ferritic	Non hardened	200	60-100	0.04	0.2
	12		Hardened	330	40-60	0.03	0.15
	13	Stainless steel Austenitic	Austenitic	180	50-90	0.04	0.2
	14		Super Austenitic	200	40-60	0.04	0.15
	15	Stainless steel Cast Ferritic	Non hardened	200	40-60	0.04	0.2
	16		Hardened	330	30-50	0.03	0.15
	17	Stainless steel Cast austenitic	Austenitic	200	40-60	0.04	0.2
	18		Hardened	330	30-50	0.03	0.15
K Cast Iron	28	Malleable Cast iron	Ferritic (short chips)	130	50-70	0.02	0.25
	29		Pearlitic (long chips)	230	50-70	0.01	0.25
	30	Grey cast iron	Low tensile strength	180	50-70	0.02	0.4
	31		High tensile strength	260	40-60	0.01	0.4
	32	Nodular SG iron	Ferritic	160	50-70	0.02	0.4
	33		Pearlitic	260	60-80	0.01	0.4
N(K) Non-Ferrous Metals	34	Aluminium alloys Wrought	Non aging	60	100-300	0.03	0.5
	35		Aged	100	100-150	0.03	0.5
	36	Aluminium alloys	Cast	75	100-150	0.03	0.5
	37		Cast & aged	90	60-100	0.03	0.5
	38	Aluminium alloys	Cast Si 13-22%	130	100-150	0.02	0.5
	39	Copper and Copper alloys	Brass	90	60-100	0.03	0.5
	40		Bronze and non leaded copper	100	60-100	0.03	0.5
S(M) Heat Resistant Material	19	High temperature alloys	Annealed (Iron based)	200	25-45	0.04	0.2
	20		Aged (Iron based)	280	20-30	0.03	0.15
	21		Annealed (Nickel or Cobalt based)	250	15-20	0.01	0.15
	22		Aged (Nickel or Cobalt based)	350	10-15	0.01	0.15
	23	Titanium alloys	Pure 99.5 Ti	400Rm	60-100	0.02	0.15
24	α+β alloys		1050Rm	40-50	0.02	0.15	
H(K) Hardened Material	25	Extra hard steel	Hardened & tempered	45-50HRc	20-45	0.01	0.05
	26			51-55HRc	20-40	0.01	0.05

Carbide Grade - VBX



General use carbide grade for Microscope inserts. TiCN coated.

Machining Recommendation

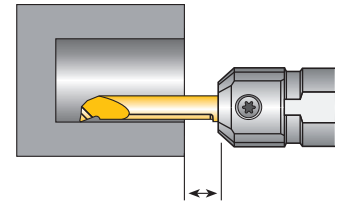

When encountering chip flow evacuation problems, it is recommended to increase the distance between the work piece and sleeve.

*Minimum cutting speed for small holes should be 25 m/min.

Threading Technical Data

Recommended Grades and Cutting Speeds Vc [m/min]

Material Group	Vargus No.	Material	Hardness Brinell HB	Vc[m/min]* VBX (Coated)
P Steel	1	Unalloyed steel	Low carbon (C=0.1-0.25%)	125
	2		Medium carbon (C=0.25-0.55%)	150
	3		High carbon (C=0.55-0.85%)	170
	4	Low alloy steel (alloying elements ≤5%)	Non hardened	180
	5		Hardened	275
	6		Hardened	350
	7	High alloy steel (alloying elements >5%)	Annealed	200
	8		Hardened	325
	9	Cast steel	Low alloy (alloying elements <5%)	200
	10		High alloy (alloying elements >5%)	225
M Stainless Steel	11	Stainless steel Ferritic	Non hardened	200
	12		Hardened	330
	13	Stainless steel Austenitic	Austenitic	180
	14		Super Austenitic	200
	15	Stainless steel Cast Ferritic	Non hardened	200
	16	Stainless steel Cast austenitic	Hardened	330
	17		Austenitic	200
	18	Hardened	330	
K Cast Iron	28	Malleable Cast iron	Ferritic (short chips)	130
	29		Pearlitic (long chips)	230
	30	Grey cast iron	Low tensile strength	180
	31		High tensile strength	260
	32		Nodular SG iron	160
33	Nodular SG iron	Pearlitic	260	
34		Aluminium alloys Wrought	Non aging	60
N(K) Non-Ferrous Metals	35	Aluminium alloys Wrought	Aged	100
	36		Cast	75
	37	Aluminium alloys	Cast & aged	90
	38		Cast Si 13-22%	130
	39	Copper and Copper alloys	Brass	90
	40		Bronze and non leaded copper	100
S(M) Heat Resistant Material	19	High temperature alloys	Annealed (Iron based)	200
	20		Aged (Iron based)	280
	21		Annealed (Nickel or Cobalt based)	250
	22		Aged (Nickel or Cobalt based)	350
	23	Titanium alloys	Pure 99.5 Ti	400Rm
24	α+β alloys		1050Rm	
H(K) Hardened Material	25	Extra hard steel	Hardened & tempered	45-50HRc
	26		51-55HRc	20-40

Carbide Grade - VBX



General use carbide grade for Microscope inserts. TiCN coated.

Calculation of N [RPM]

$$N = \frac{1000 \times V_c}{\pi \times D}$$

$$V_c = \frac{N \times \pi \times D}{1000}$$

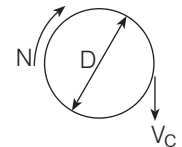

N - Revolution Per Minute [RPM]

V_c - Cutting Speed [m/min]

D - Workpiece Diameter [mm]

Number of Passes for Threading

Pitch	mm	0.50	0.75	1.00	1.25	1.50	1.75	2.00
tpi		48	32	24	20	16	14	12
No. of passes (Microscope)		6-9	6-11	6-12	8-14	9-15	11-18	11-18

*Minimum cutting speed for small holes should be 25 m/min.



microscope
Micro Tools For Small Bores

GROOVEX
Innovative Grooving Solutions

maxmark
METRIC